



PIPE TOOLS & VISES
SINCE 1896



FT2000UNIV

Feed Tap™

Operating Instructions

SAVE THESE INSTRUCTIONS!

PRODUCT INFORMATION

Reed's Feed Tap™ drills through PVC, PE, cast iron and ductile iron pipe while under pressure using a corporation stop inserted into a service saddle. The compact design, featuring a separate, independent feed control for advancing the heavy-duty shell cutter into the pipe, allows the user to easily complete the tap using a drill for cast and ductile iron, or manual power for PVC/PE and other plastic pipe. The independent feed control advances the shell cutter for tapping PVC pipe as recommended by Uni-Bell PVC Pipe Association.

CAUTION:

Hazards exist when drilling into pressurized pipe. Hazards also exist when drilling into unpressurized pipe as it could fail when it becomes pressurized. If the tapping process is performed improperly, C900 and other PVC pipe can split longitudinally. To minimize the risks when performing the tap, apply minimum feed force to the shell cutter and always use sharp shell cutters.

Note: Use correctly sized saddles and evenly tighten each clamp nut and torque the nuts to values recommended by the saddle manufacturer. If tapping into PVC or PE, make sure the tapping saddles are made for use with plastic and provide full circumferential support.

MAKE SURE drill is set in non-hammer mode.

DO NOT USE impact type drills.

DO NOT USE on natural gas or petroleum piping.

REED MANUFACTURING COMPANY

1425 WEST EIGHTH ST. ERIE, PA 16502 USA

PHONE: 800-666-3691 OR 814-452-3691 FAX: 800-456-1697 OR 814-455-1697

www.reedmfgco.com

0517-59160

FEED TAP™ OPERATING INSTRUCTIONS

WARNING: The maximum operating pressure for this tool is 200 psi.

NOTE: Absolutely **no power tools** are to be used to turn Feed Tap™ machines to cut PVC/PE or any other type of plastic pipe. Use **manual power** instead.

1. Select proper tools necessary to perform the tap.

- A. Corporation stop.
- B. Shell Cutter size to match corporation stop.
 - Arbor must be used with 1-7/16" and 1-3/4" Shell Cutters.
- C. Coupon retaining pilot drill.
 - Always use with Reed Heavy Duty Shell Cutters.
 - Optional when using Reed PVC/PE Shell Cutters
- D. Proper size and design of service saddles for Ductile Iron, Cast Iron, PVC and PE.
- E. Feed Tap™.
- F. Any other necessary accessories to meet operating requirements.
- G. Appropriate Personal Protective Equipment (PPE).

2. Assemble Feed Tap™ to the pipe.

- A. Clean area of pipe where drilling will occur.
 - On ductile iron and cast iron pipe use a Reed DS12 or DS36 Descaler.
- B. Place service saddle on the pipe and tighten down to values specified by the manufacturer.
- C. Attach the appropriate corporation stop valve to the service saddle.
- D. Assemble the Feed Tap™ with the correct size corporation adapter, shell cutter and the coupon retaining pilot drill. For optimum thread life, use plumber's thread seal tape on the male threads of the main sealing unit prior to attaching the corporation adapter.

NOTE: The 1" IPS Coupling Nut must be used with the 1" AWWA - 110 Compression Corporation Adapter.

- E. Lubricate the teeth of the shell cutter generously with Reed Tapping Compound #98425 or #99139.
- F. Lubricate the o-ring inside the corporation adapter with tapping compound. This does not apply to the NPT corporation adapters.
- G. Attach the Feed Tap™ to the corporation stop.
- H. Verify corporation stop will shut with shell cutter and shaft retracted.

HELPFUL HINT: Take note of, or measure, the location of the Independent Feed Control so that upon retracting the cutter back out of the pipe and valve, you know how far to retract it to allow the valve to close.

- I. Attach the drill motor onto the boring bar of the Feed Tap™ and tighten the chuck.

NOTE: Use of a hand ratchet is required when tapping PVC/PE or other plastic pipe. Do not use a powered drill.

- J. Open the bleed-off valve.

3. Completing the Tap

- A. Open the corporation stop and the bleed-off valve on the Feed Tap™.
- B. Using the independent feed control, bring the tool in contact with the pipe surface. Do not run the drill motor without controlling the independent feed control, by hand, at all times. The feed control can self feed too quickly if it is not controlled constantly by the operator. If it self feeds, the coupon retaining pilot drill could jam into the pipe which would damage or break it. The user must always keep ahold of the independent feed control when the boring bar is in motion.
- C. Drill through the pipe by rotating the drill clockwise and applying slow steady pressure using the independent feed, **turn in a clockwise direction**. Water coming from the bleed off valve does not indicate the shell cutter has completed its cut. The operator will notice that there is no more resistance when turning the Independent Feed once the shell cutter completes the cut through the pipe wall.

NOTES:

- The **slow speed setting** on the drill motor is recommended. This gives the user the best control of the tool and is best for the longevity of the carbide shell cutters and pilot drill.

WARNING: Give the feed screw a **couple extra turns** to ensure that the shell cutter has completely cut through the pipe wall. If the coupon is not completely cut, it could strip off the coupon retaining bit when retracting the shell cutter back out of the pipe.

4. Tool Removal and Storage

- A. Once the tap is completed, close the bleed-off valve and reverse the direction of the independent feed, **turn in a counter clockwise direction** to retract the shell cutter out of the pipe and corporation stop. The **drill motor** can be stopped and removed from the Feed Tap prior to backing out the tool from the pipe. **Do not** reverse the drill motor direction and use it to back the tool out of the pipe. Doing so could cause the tools on the end of the boring bar to unscrew and drop off.
- B. Turn off the corporation stop and the Feed Tap™ can be removed by disassembling the corporation adapter from the corporation stop valve.
- C. Remove coupon from shell cutter.
 - Remove the Coupon Retaining Pilot Drill Bit by loosening the set screw.
 - Use a screwdriver in the slot of the Shell Cutter to remove the coupon if necessary.

Assembly of Feed Tap™

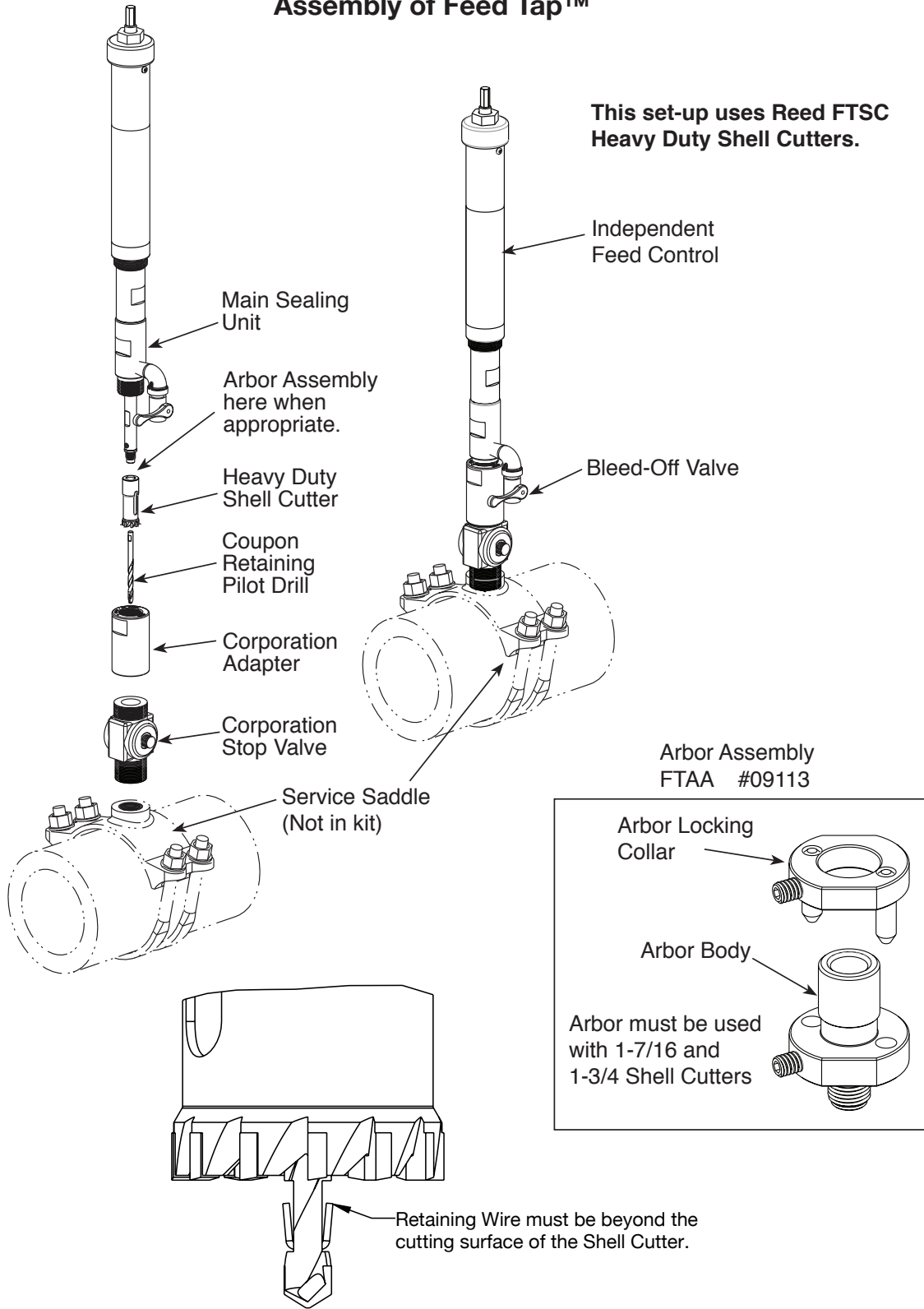

Arbor Instructions:

Arbor attaches directly to the end of the shaft then the Pilot Drill and Shell Cutter attach to the Arbor. Attach the pilot drill by aligning the flat that is machined onto it, then tighten the set screw. Next thread the shell cutter onto the arbor until it snugs down onto the o-ring, align the locking holes, then slide the arbor locking collar into place and tighten the set screw.

FEED TAP™ OPERATING INSTRUCTIONS

Assembly of Feed Tap™ for Plastic Only.

FTP2000UNIV #09168

*Includes Ratchet Wrench and Socket

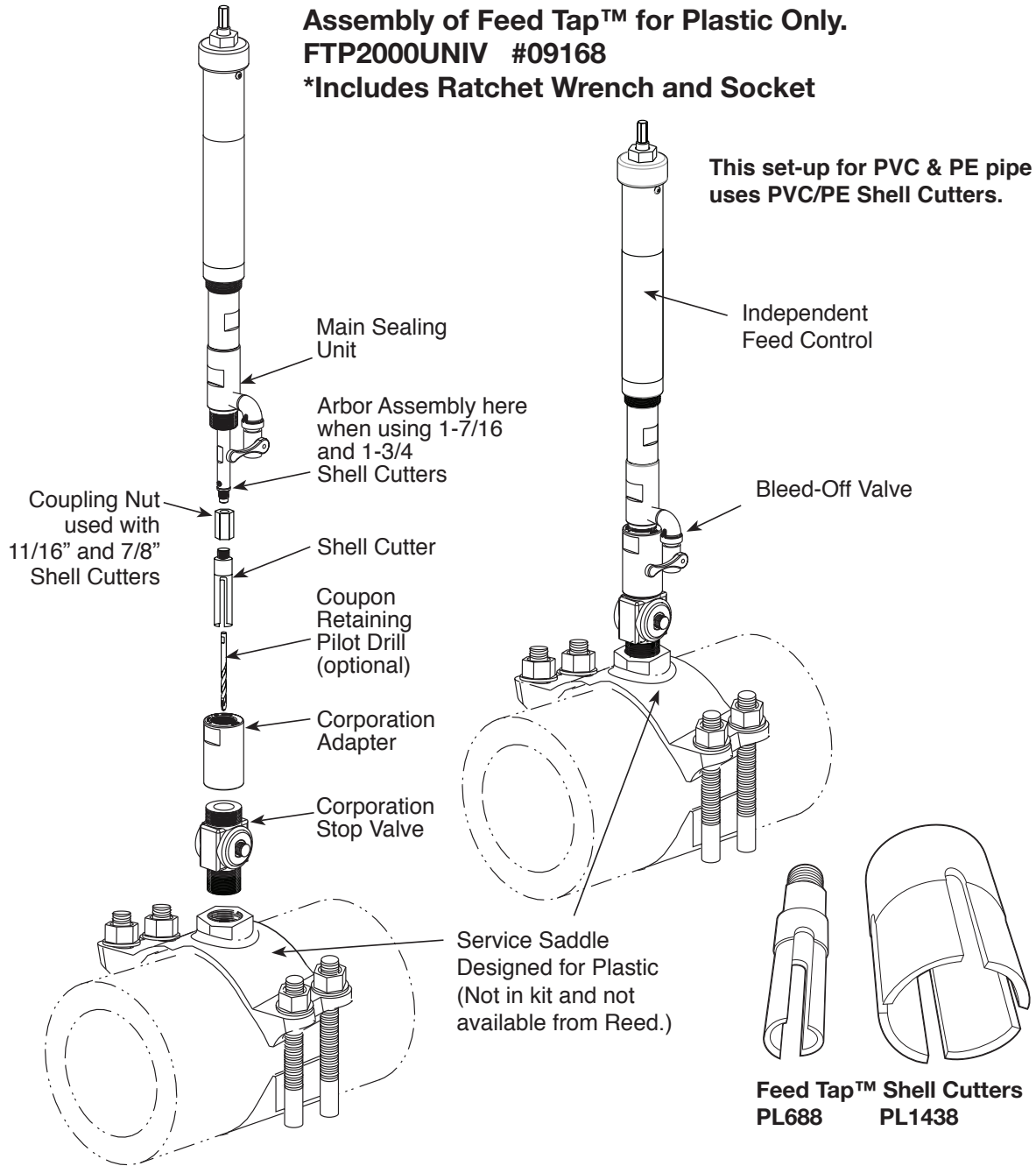

NOTE: Absolutely **no power tools** are to be used to turn Feed Tap™ machines to cut plastic pipe.



Attach coupling nut to shell cutter.

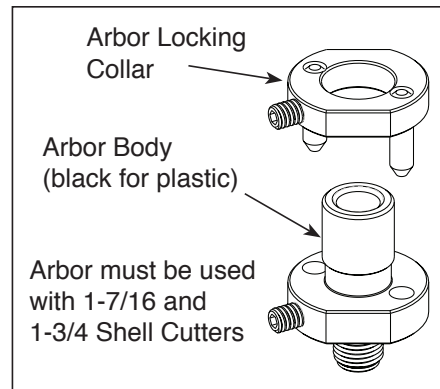

Arbor Assembly for Plastic Only
FTPLAA #04423

FEED TAP™ OPERATING INSTRUCTIONS

WARNING: The coupon will not come off over the end of the pilot drill bit. Doing so will damage the integrity of the wire coupon retainer. The pilot drill must be removed in order to remove the coupon from the tool. It is not recommended to use a coupon retaining pilot drill that has signs of damage.

- D. Further disassemble the Feed Tap™ as needed to fit in carrying case.

HELPFUL HINT:

- A. If wobbling occurs while drilling:
 - 1. Loosen the drill chuck from the shaft and reconnect. Typically the chuck jaws are not aligned with the shaft flats.
 - 2. Replace shell cutter if wobbling continues.

NOTE: When removing the shell cutter from the boring bar, grip onto the base of shell cutter with pliers. Gripping onto the shell cutter in the middle of the body or near the cutting end could distort it, causing it to work improperly.

NOTE: Do not use shell cutters or pilot drills that have missing, worn or dull carbide.

OPTIONAL OPERATING INSTRUCTIONS WHEN USING MAGNETIC COUPON RETAINERS:

WARNING: The maximum operating pressure for this tool is 200 psi.

1. Select proper tools necessary to perform the tap.

- A. Corporation stop.
- B. Shell Cutter size to match corporation stop.
 - Arbor must be used with 1-7/16" and 1-3/4" Shell Cutters.
- C. Proper size service saddles for ductile iron/cast iron.
- D. Feed Tap™
- E. Any other necessary accessories to meet operating requirements.
- F. Appropriate Personal Protective Equipment (PPE).

2. Assemble Feed Tap™ to the pipe.

- A. Clean area of pipe where drilling will occur. On ductile iron and cast iron pipe use a Reed DS12 or DS36 Descaler.
- B. Place service saddle on the pipe and tighten down. If on plastic, use saddles designed for plastic, evenly tighten the clamp nuts and turn to torque values specified by the manufacturer.
- C. Attach the appropriate corporation stop valve to the service saddle.
- D. Assemble the Feed Tap™ with the correct size corporation adapter, pilot drill, shell cutter, and magnetic coupon retainer. For optimum thread life, use plumber's thread seal tape on the male threads of the main sealing unit prior to attaching the corporation adapter.

NOTE: The 1" IPS Coupling Nut must be used with the 1" AWWA - 110 Compression Corporation Adapter.

- E. Lubricate the teeth of the shell cutter generously with Reed Tapping Compound #98425 or #99139.
- F. Lubricate the o-ring inside the corporation adapter with Reed tapping compound. This does not apply to NPT corporation adapters.
- G. Attach the Feed Tap™ assembly to the corporation stop. Tighten the corp adapter to the corp stop using the RCORP wrench.
- H. Verify corporation stop will shut with pilot drill and shaft retracted.

HELPFUL HINT: Take note of, or measure, the location of the Independent Feed Control so that when you are retracting the cutter back out of the pipe and valve you know how far you have to retract it in order to allow the valve to close.

- I. Attach the drill motor onto the boring bar of the Feed Tap™ and tighten the chuck.
- J. Open the bleed-off valve.

3. Completing the Tap

- A. Open the corporation stop and the bleed-off valve on the Feed Tap™.
- B. Using the independent feed control, bring the tool in contact with the pipe surface. Do not run the drill motor without controlling the independent feed control, by hand, at all times. The feed control can self feed too quickly if it is not controlled constantly by the operator. If it self feeds, the pilot drill could jam into the pipe which would damage or break it. The user must always keep ahold of the independent feed control when the boring bar is in motion.
- C. Drill through the pipe by rotating the drill clockwise and applying slow steady pressure using the independent feed, **turn in a clockwise direction**. Water coming from the bleed off valve does not indicate the shell cutter has completed its cut. The operator will notice that there is no more resistance when turning the Independent Feed once the shell cutter completes the cut through the pipe wall.

NOTE: The **slow speed setting** on the drill motor is recommended. This gives the user the best control of the tool and is best for the longevity of the carbide shell cutters and pilot drill. Higher speeds will create excessive heat and also dislodge magnets resulting in lost coupon.

FEED TAP™ OPERATING INSTRUCTIONS

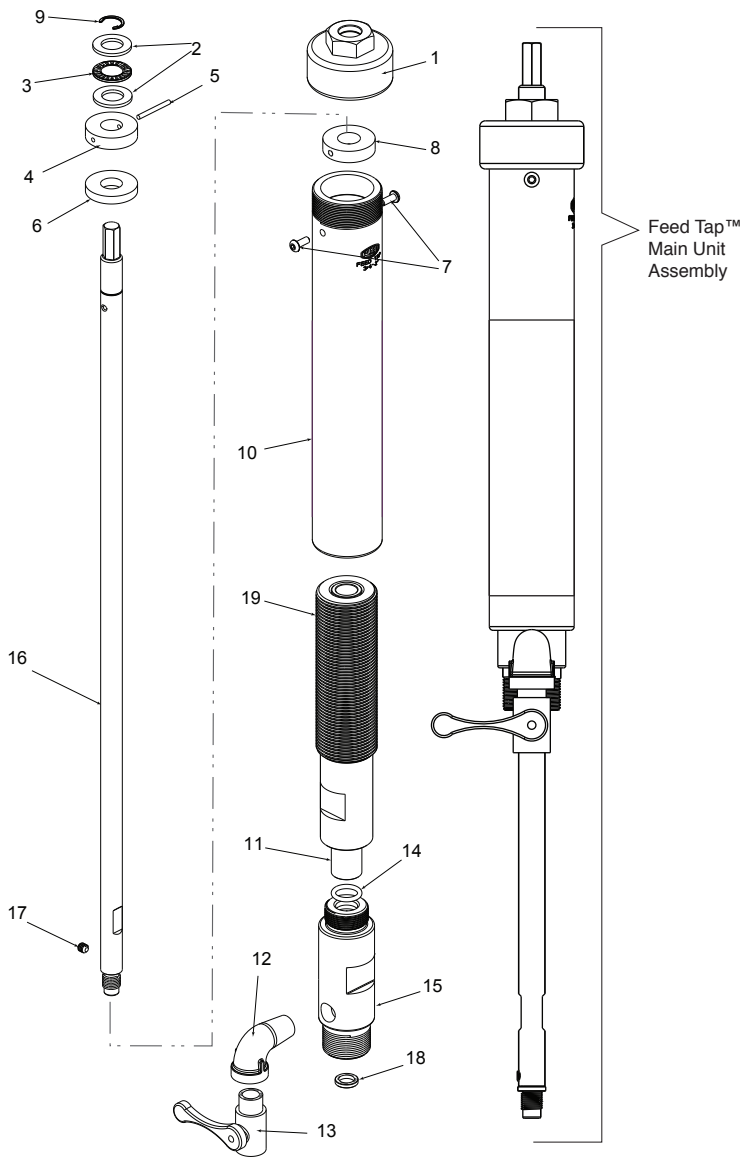

WARNING: Give the feed screw a **couple extra turns** to ensure that the shell cutter has completely cut through the pipe wall. If the coupon is not completely cut, it could strip off the coupon retaining magnet when retracting the shell cutter back out of the pipe.

4. Tool Removal and Storage

- A. Once the tap is completed, close the bleed-off valve and reverse the direction of the independent feed, **turn in a counter clockwise direction** to retract the shell cutter out of the pipe and corporation stop. The **drill motor** can be stopped and removed from the Feed Tap prior to backing out the tool from the pipe. **Do not** reverse the drill motor direction and use it to back the tool out of the pipe. Doing so could cause the tools on the end of the boring bar to unscrew and drop off.
- B. Turn off the corporation stop and the Feed Tap™ can be removed by disassembling the corporation adapter from the corporation stop valve.
- C. Remove coupon from shell cutter.
 - Remove the Coupon Retaining Pilot Drill Bit by loosening the set screw.
 - Use a screwdriver in the slot of the Shell Cutter to remove the coupon if necessary.
- D. Further disassemble the Feed Tap™ as needed to fit in carrying case.

HELPFUL HINT:

- A. If wobbling occurs while drilling:
 1. Loosen the drill chuck from the shaft and reconnect. Typically the chuck jaws are not aligned with the shaft flats.
 2. Replace shell cutter if wobbling continues.

NOTE: When removing the shell cutter from the boring bar, grip onto the base of shell cutter with pliers. Gripping onto the shell cutter in the middle of the body or near the cutting end could distort it, causing it to work improperly.

NOTE: Do not use shell cutters or pilot drills that have missing, worn or dull carbide.

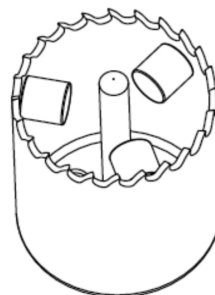

OPTIONAL: To use magnets as coupon retainer, place magnets in orientation as shown in diagram. Use 1/4" diameter magnets for 3/4"-1" diameter Shell Cutters. Use 3/8" diameter magnets for 1-7/16" to 1-3/4" diameter. Do not use magnets on shell cutters larger than 1-3/4" diameter.

ITEM	DESCRIPTION	ITEM CODE	QTY.
1	FEED NUT CAP ASSEMBLY	99272	1
2	BEARING THRUST WASHER	49161	2
3	NEEDLE THRUST BEARING	49160	1
4	FEED THRUST WASHER	99162	1
5	HEAVY NATURAL SPIROL PIN	30000	1
6	RULAN BEARING WASHER	49163	1
7	LG BUTTON HD SOC CAP SCR	39161	2
8	RETRACTION THRUST WASHER	99163	1
9	BEARING RETAINING RING	49162	1
10	FEED NUT	99261	1
11	BRONZE BEARING	99103	1
12	90° STREET ELBOW	49142	1
13	BALL VALVE	48161	1
14	O-RING	39119	1
15	CYLINDER	99102	1
16	BORING BAR	99260	1
17	LG HALF DOG POINT	36462	1
18	THREADED WASHER	99101	1
19	FEED SCREW ASSEMBLY	99274	1

FEED TAP™ OPERATING INSTRUCTIONS

Corporation Adapters

Cat. No.	Item Code	Description
FT75CC110	09170	3/4" AWWA and 110 Comp
FT100CC110	09171	1" AWWA and 110 Comp
FT150	09172	1-1/2" AWWA
FT200	09174	2" AWWA
FT150110	09173	1-1/2" 110 Comp
FT200110	09175	2" 110 Comp
DMCA100IPS*	98499	1" IPS
FT75NPT	99117	3/4" NPT
FT100NPT	99118	1" NPT
FT150NPT	99109	1-1/2" NPT
FT200NPT	99112	2" NPT

*Requires #09171 adapter.

Heavy-Duty Shell Cutters

Shell cutters cut up to 2" deep and fit most standard arbors and competitive machines. Cut cast iron, ductile iron and PVC. The attachment thread is 1/2 - 20. Each tooth has carbide inserts which long outlast bi-metal teeth.

Cat. No.	Item Code	Shell Cutter Size Inches*
FTSC688	99132	11/16
FTSC875	99134	7/8
FTSC1438	99137	1-7/16
FTSC1750	99138	1-3/4

*Check manufacturer's fitting specifications for proper hole diameter.

PVC/PE Shell Cutters

- Tool steel is heat-treated for optimum toughness and wear resistance.
- Flute design offers easy cutting and constant coupon retention.
- Cut PE & PVC.

Cat. No.	Item Code	Shell Size in	Nom. Corp. Size in.*
PL688	04385	11/16	3/4"
PL875	04386	7/8	1"
PL1438	04387	1-7/16	1-1/2"
PL1750	04392	1-3/4	2"

*Check manufacturer's fitting specifications for proper hole diameter.

Miscellaneous

Cat. No.	Item Code	Description
FTPLAA	04423	Adapter used with 1-1/2" & 2" PVC/PE Shell Cutters
DMP716	04428	Ratchet Wrench
L716	04429	7/16" Socket
FTAA	09113	Arbor Assembly used with 1-7/16 & 1-3/4 FTSC Shell Cutters
FTPSAA	94198	Adapter used with 3/4" & 1" PVC/PE Shell Cutters
CRPD25	99129	1/4" diameter Carbide Tipped Coupon Retaining Drill Bit

TOOL CARE AND MAINTENANCE

- The o-ring should be lubricated regularly with grease. Reed Tapping Compound may be used for this purpose.

Lubricate the o-ring by disassembling the Main Sealing Unit from the Feed Screw using the wrench flats. Apply grease to the shaft and o-ring and reassemble. It is not necessary to completely take the Main Sealing Unit off the Boring Bar (Shaft). If it is necessary to remove the Main Sealing Unit from the Boring Bar, the following items must be removed first: any Shell Cutters, any Magnetic Coupon Retainers, the Pilot Drill Bit, and the Threaded Washer on the end of the Boring Bar. Also make sure that the Set Screw that holds in the Pilot Drill Bit is either removed or screwed in so that it is not sticking out beyond the surface of the shaft.

- Keep the threads on the independent feed nut and screw clean. Build up in the threads will cause wear and make the tool difficult to use. If cleaning is needed, use a soft bristle brush and water.
- Magnetic Coupon Retainers should be wiped clean after use.



Reed Lifetime Warranty

Reed Hand Tools are for the professional trade and are warranted against all failure due to defects in workmanship and materials for the normal life of the tool.

FAILURES DUE TO MISUSE, ABUSE, OR NORMAL WEAR AND TEAR ARE NOT COVERED BY THIS WARRANTY.

Power units for Universal Pipe Cutters, Saw It® pneumatic saw, hydrostatic test pumps, cordless power pipe bevelers, and threading power drives are warranted for a period of one year from date of purchase. Hydraulic pumps for PE Squeeze-Off tools have a one year warranty from date of purchase.

NO PARTY IS AUTHORIZED TO EXTEND ANY OTHER WARRANTY. NO WARRANTY FOR MERCHANTABILITY OR FITNESS FOR A PARTICULAR PURPOSE SHALL APPLY.

No warranty claims will be allowed unless the product in question is received freight prepaid at the Reed factory. All warranty claims are limited to repair or replacement, at the option of the company, at no charge to the customer. REED IS NOT LIABLE FOR ANY DAMAGE OF ANY SORT, INCLUDING INCIDENTAL AND CONSEQUENTIAL DAMAGES. Some states do not allow the exclusion or limitation of incidental or consequential damages, so the above exclusion may not apply.

This warranty gives you specific legal rights, and you may also have other rights which vary from state to state.

REED MANUFACTURING COMPANY
1425 WEST EIGHTH ST. ERIE, PA 16502 USA
PHONE: 800-666-3691 OR 814-452-3691 FAX: 800-456-1697 OR 814-455-1697
www.reedmfgco.com